



***DESIGN.
DELIVER.
DONE.***



VIEWRAIL
RAILING + FLOATING STAIRS



Modern strength has never been so simple.

Floating stairs have always been a fab-on-site nightmare...until now. *Viewrail Flight* unites rock solid construction with effortless beauty in a system that arrives ready to install. No cutting. No welding. Simply bolt the monostringer in place.

How can it be this easy?

Each Flight is custom engineered to your exact finished-floor-to-finished-floor measurements, then custom built and setup in our facility to ensure all angles are accurate and all tread brackets are level.

A Complete System

Every floating stair system needs thick treads and sleek railing to compliment the high style of its surroundings. At Viewrail, we offer a full line of thick treads in a variety of sizes and over 20 different wood species. And as you'll see in the following pages, we also make railing solutions that lead the industry in elegance: simple to install, simple to love.

Call today to discover the possibilities.

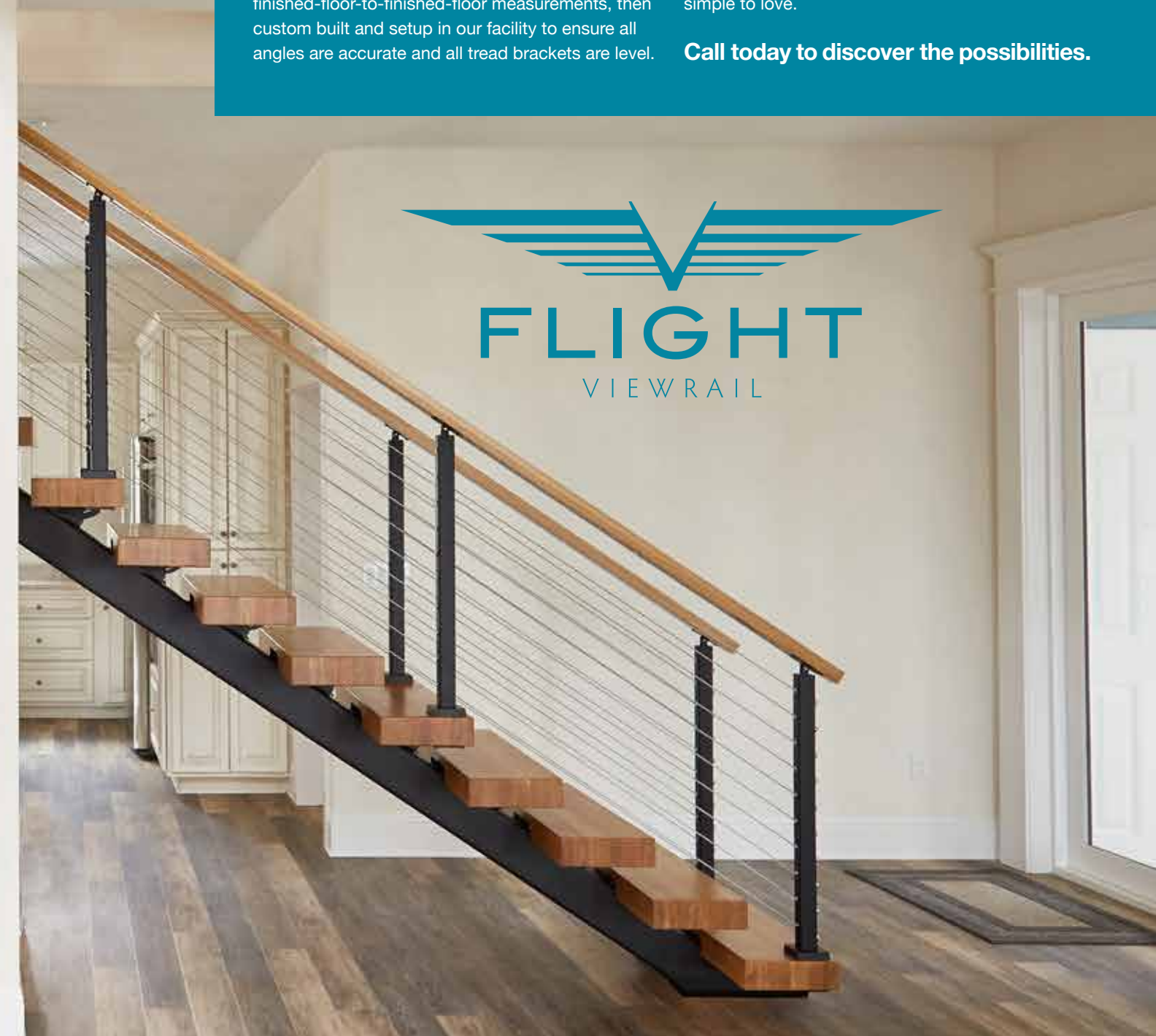

Let's get to the point:
We make this job easier.

DESIGN.

Whether you're looking for glass, cable, or stainless steel rods, you'll find that our posts and infill options have been designed to exceed expectations.

Your railing project will get off the ground with Victor, our online design and quoting app. From there, our highly skilled design team will make sure it all looks right. They've been there, and they've done that; bringing years of experience to every job. They take special pride in listening to the unique needs of each project.

Long story short, we'll get you the right products and the tools you'll need to install them.



DELIVER.

Combining well-trained employees with killer tech like lasers, robotic welders, and space-age mills, we keep lead times low and quality high. We even solved the ancient mystery of how to powder coat with speed *and* amazing quality.

Keeping all of our finishing in-house gets product on a truck to your job site faster.



DONE.

This is what everyone wants: the job is done & and the client is thrilled. We do everything we can to help you get there ASAP. Detailed written instructions, video installation examples, and customer support will have you and your crew moving to the next job in no time.

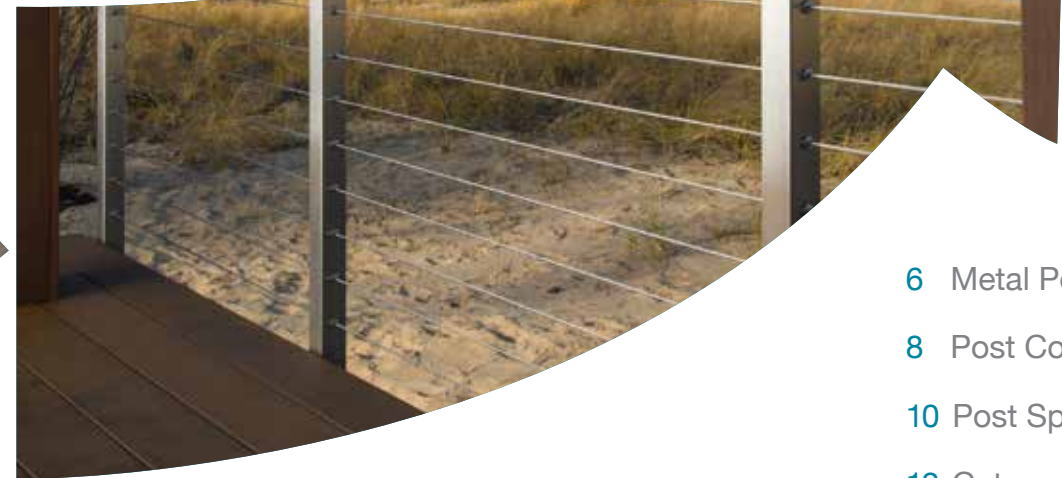

LET'S GO.

- 6 Metal Posts
- 8 Post Configurations
- 10 Post Specifications
- 12 Gates
- 14 Handrail
- 16 Glass & Slim Rod Infill
- 20 Cable Railing Infill
- 24 Crimpless Cable
- 26 Tools & Warranty

Metal Posts



Mounting Options

Viewrail manufactures posts in the five mounting styles shown below. Since all of our posts are built to order, they can be made with an Angle Foot mount at a precise angle or drilled with custom hole spacing. Whatever tweaks you need to make it just right, we can make it happen for you.

Post Tops

Our posts are available in Universal Top or Flat Top configurations. The Flat Top is made only for level runs, while the Universal Top handles level and angle runs with strength and grace.

Materials & Finishes

Our post materials have been carefully chosen for beauty and strength. These materials include 2205 marine-grade stainless steel, 304 stainless steel, and aluminum.

We offer a brushed finish as well as powder coat finishes in the colors shown (at right).

Electropolishing

Electropolishing stainless steel increases its natural resistance to corrosion. This process is highly recommended for any installations in a marine environment.

Foot Covers

Foot Covers slide over the post and cover the mounting screws to further drive home the Viewrail look of simplicity and elegance.

Split Foot Covers are available for Rods installations or to be added to any post after installation. Foot Covers and Split Foot Covers are also available in a variety of angles for our Angle Foot Posts.



Side Mount (fascia mount)

Slim Side Mount (fascia mount)

Side Mount Bump Out (fascia mount)

Core Drill

Special Application (concrete mount)

Surface Mount w/ Foot Cover

Angle Foot Post w/ Foot Cover

Universal Top for Level or Angle

Flat Top Level runs only



Black



Copper Vein



Fashion Grey



Colonial Grey



Bone White



Apollo White

Post Configurations



The Complete System

The Viewrail system offers post configurations that can handle all of your normal railing layouts, as well as some more challenging designs. Our goal is to provide you with a system that is complete: saving your time and sanity by spending less time figuring out workarounds.

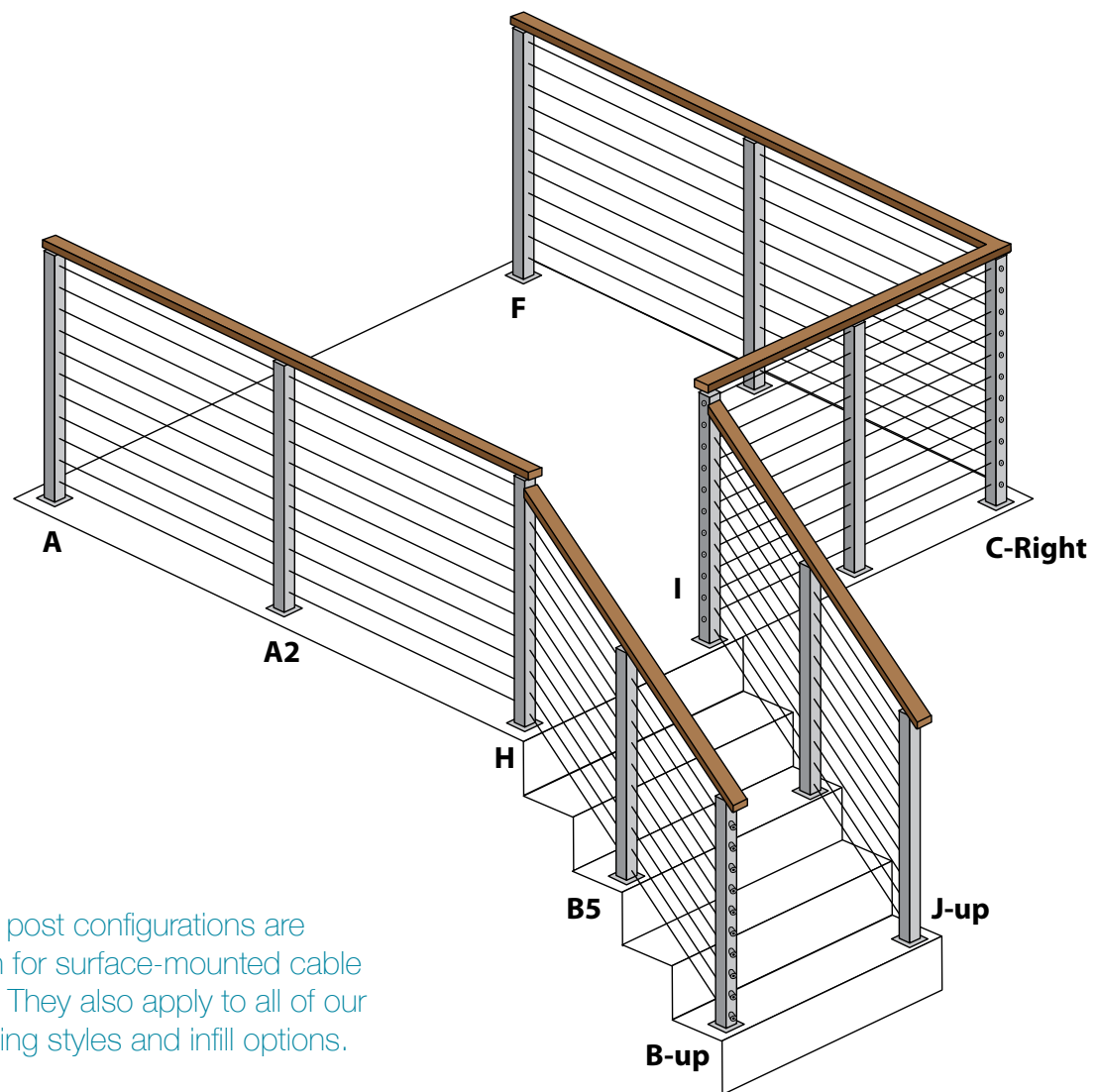

These post configurations are shown for surface-mounted cable railing. They also apply to all of our mounting styles and infill options.

A complete system gets the job done right, and on time.

The A Post

The A post can be used as an end post or a line post (A2) for level cable runs. When used as an end post, it terminates cable runs with a Tension Receiver.

The B Post

The B post is used as an end post, and the B5 is a pass-through post; both are for angle cable runs. When used as an end post, it terminates cable runs with a Tension Receiver and an Angle Washer. It is available in 'up' or 'down' configurations.

The C Post

The C post is a corner post. It has 'through holes' that terminate a cable run with a Tension Receiver. At a 90° turn, the C post has a set of special keyholes for the KeyMount Fitting.

The D Post (not shown)

The D post is a corner post that transitions an angle run to a level run at a 90° turn, just like the I post shown in the diagram. However, the D post does not transition handrail height. So the D post is used when you need to turn a corner and maintain the same handrail height on the angle and level sides.

The F Post

The F post is an end post that uses our KeyMount system for level applications. It has keyholes in only one side of the post that receive the KeyMount Fitting.

The H Post

The H post is used to transition from a 36" angle run (10 cables) to a level run that is 39" (11 cables) or 42" (12 cables). The bottom 10 cables pass through the post while the additional cable(s) start at the top of the post via a keyhole and KeyMount Fitting. The H post often utilizes the Postside Handrail Bracket (sold separately) to attach handrail to the side.

The I Post

The I post is a corner post that transitions an angle run to a level run at a 90° turn. It can also transition handrail height from 36" on the angle run to 39" or 42" on the level run. It has through holes in both directions allowing cable runs to be terminated with a Tension Receiver and an Angle Washer. This post often utilizes the Postside Handrail Bracket (sold separately) to attach handrail to the side.

The J Post

The J post is an end post that uses our KeyMount system for angle applications. It has keyholes in one side of the post that receive the KeyMount Fitting. It is available in 'up' or 'down' configurations.

The S Post (not shown)

The S post is available in our standard 36", 39", and 42" heights, but has no holes drilled. This configuration is often used by customers who want to drill their own holes, or in applications where handrail support is desired with no infill.



Post Specifications

If standard specs aren't doing it for you, we'll make it custom.

Posts with Level Cable Runs

Hole spacing is 3 1/8" unless marked otherwise

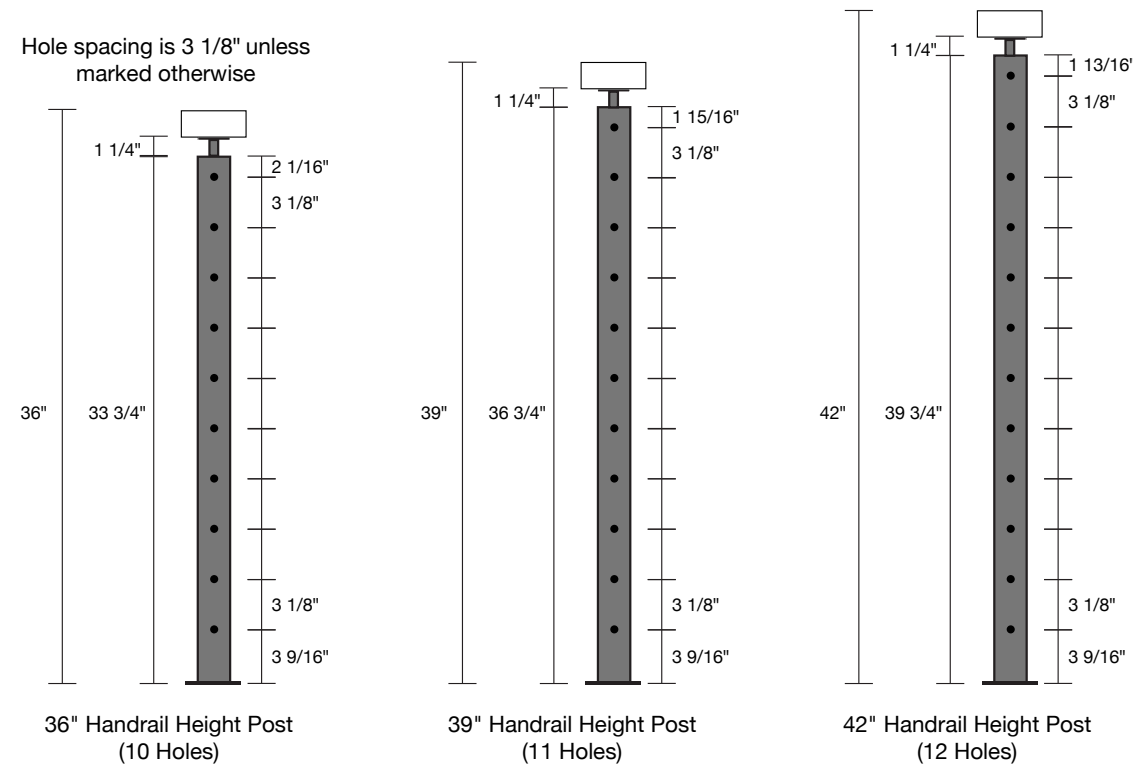

Posts with Angle Cable Runs

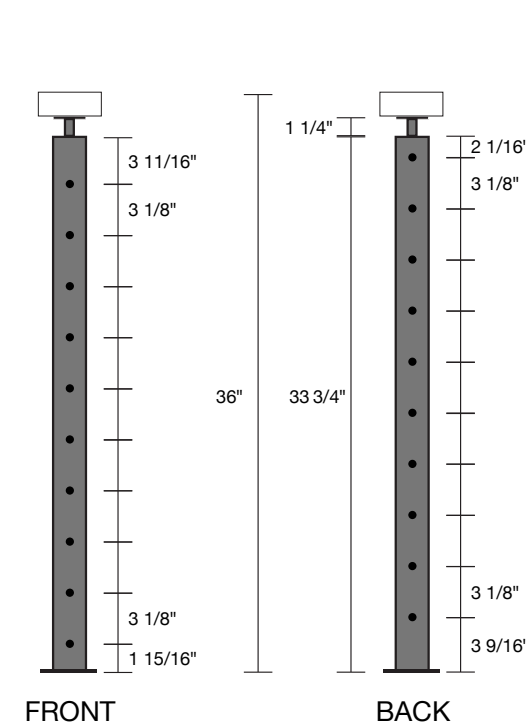

Side Mount Posts (Fascia Mount)

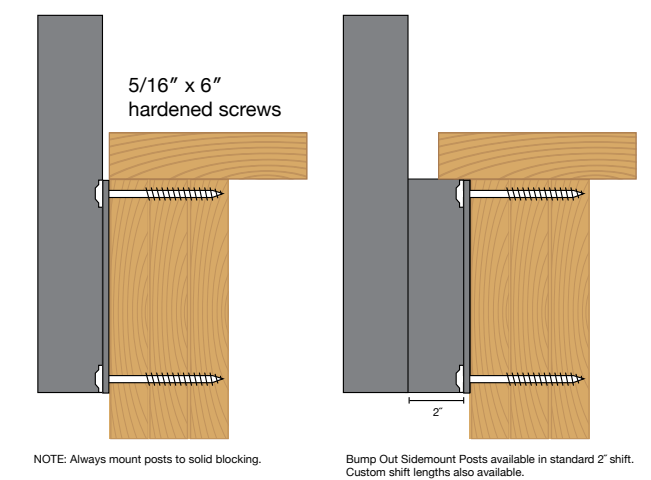
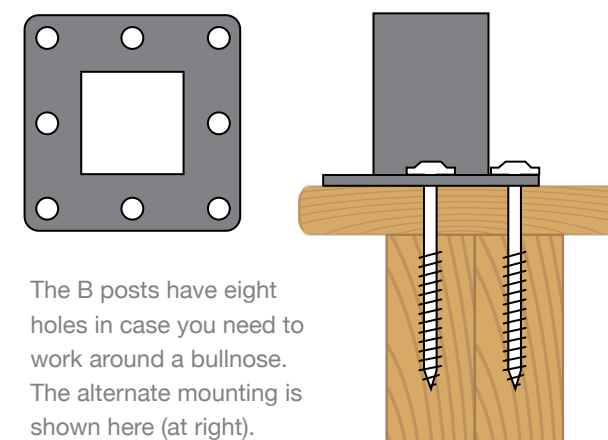
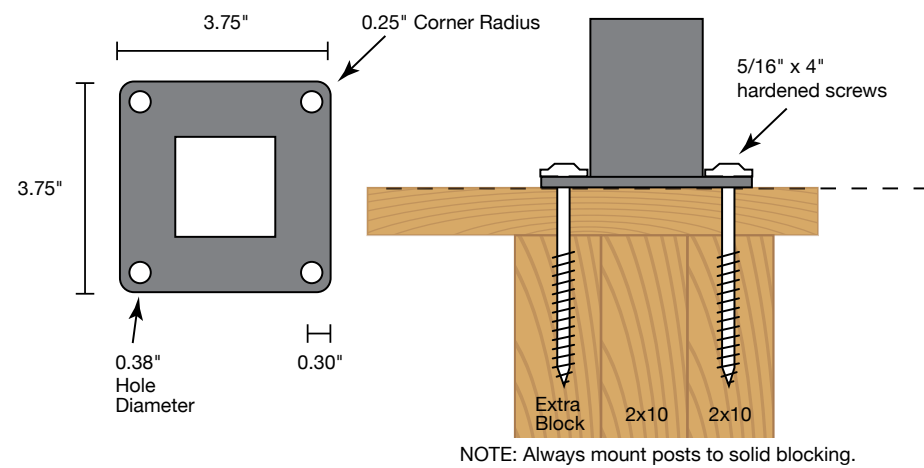
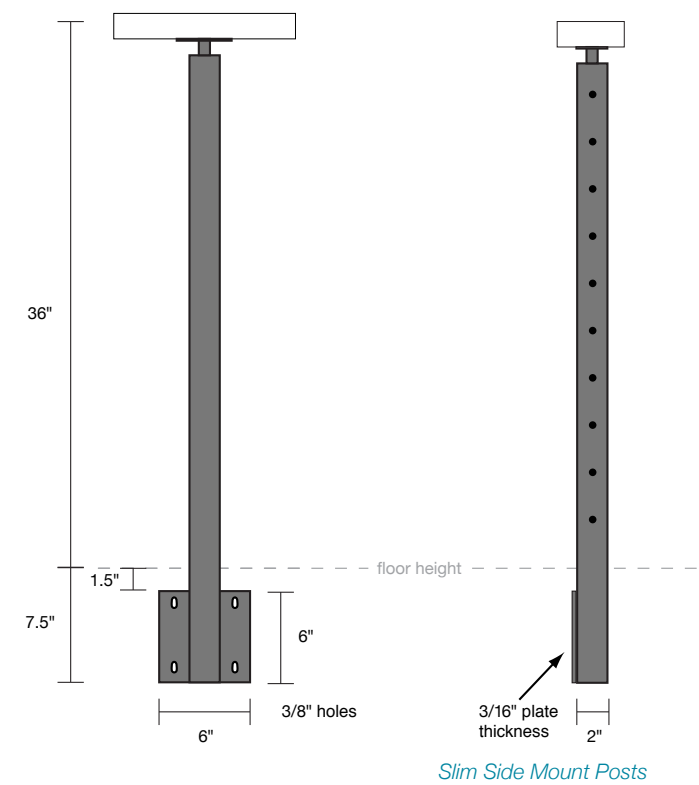

Gates



Universal Top Gate

The Universal Top Gate creates clean lines by matching the mounting look of our Universal Top posts, as well as continuous lines between cable railing and the stainless rods infill of the gate.

Flat Top Gate

The Flat Top Gate is designed to match each system's handrail height, maintaining a seamless flow. All of our gates are welded for maximum strength and durability, making safety a beautiful thing.

Gate Sizes

Height	36", 39", and 42"
Width	36", 39", 42"*, 45"*, and 48"*
*Gates 42" or wider require our robust hinge post with thicker post walls and a thicker mounting plate.	



Universal Top Gate

Flat Top Gate



Latch & Hinges

Optional Stainless Look Hinge Cover

Materials & Finishes

Viewrail Gates of all sizes are made from marine-grade stainless steel. All standard finishes are available.

Double Gates

These double gates are available for openings wider than 48" but no wider than 96". All French Door Gates require our robust hinge post.

Industry-leading Hardware

All Gates include two self-closing hinges and a magnetized latch. This gate attachment system promotes customer safety and lasting strength. Latches and hinges are shipped loose and installed on the job site. This allows the customer to choose swing direction and achieve a precise fit.

Viewrail Gates bring together form and function beautifully.



FYI & FAQ

- Hinge and Latch posts are sold separately.
- All gates have stainless steel rods as infill.
- Hinge posts need to be bolted to the mounting surface.
- The gate opening needs to be 1 1/8" wider than the gate. (example: a 36" wide gate requires a 37 1/8" opening)
- Can be ordered without latch to accommodate custom latch solutions.

Handrail

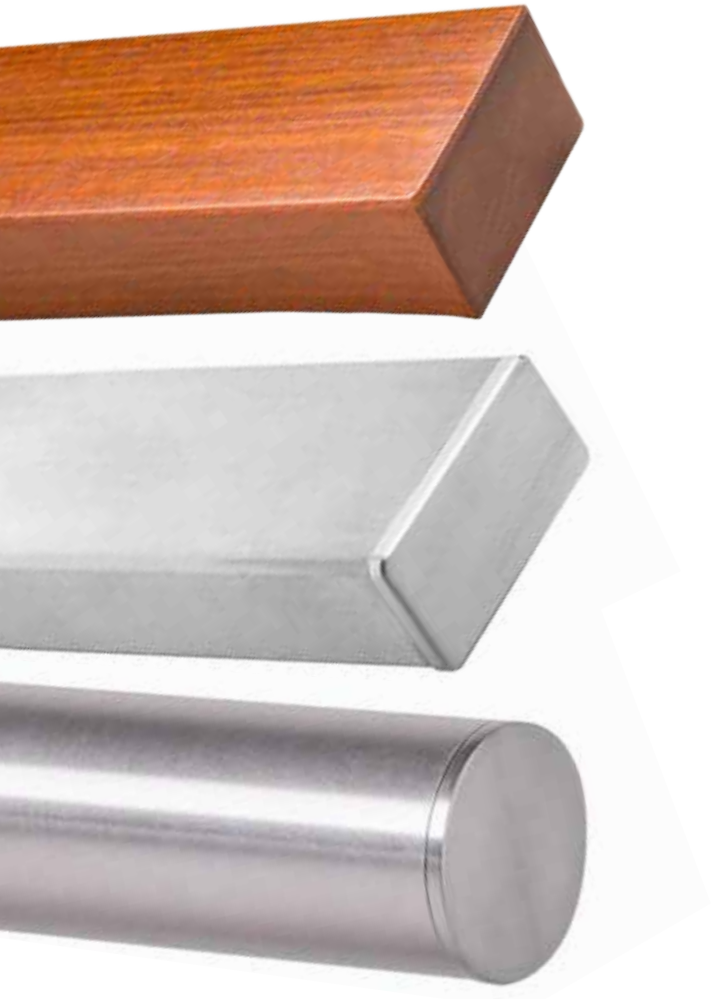

The Warmth of Wood

Wood handrail solutions are frequently used with our cable rail system. We offer architecturally correct handrails in dozens of wood species that are great for interior or exterior use. With so many species, stains, and profiles available, your design creativity can run wild.

A Modern Masterpiece

Our 1" x 2" rectangular handrail is made to perfectly compliment our 2" square posts. The combination is a simply stunning display of modern elegance. It comes in brushed marine-grade stainless steel, 304 stainless steel, or aluminum. The ends can be cut to fit on site and finished with a matching end cap.

The Circumference of Comfort

Some of our customers won't accept anything less than round handrail. They love the way it looks and feels. We craft it out of marine-grade stainless steel, perfect for a brushed finish or powder coating. We also make handrail brackets that have been specially designed to fit our round handrail.



Handrail Caps
(cover transitions)

Handrail Brackets

Handrail Screws

Handrail End Plugs

Round Handrail
Joints

Wall-mounted Handrail Brackets

Beautiful in brushed stainless or any powder coat color, these brackets will carry that signature Viewrail look throughout your railing system. The bracket projection is 3 3/16".

Grab Rail Bracket

Newest of our offerings, the Grab Rail Bracket can elegantly attach grab rail to any stainless steel post. It's easy to install and adjustable to any angle.

Postside Handrail Brackets

These brackets have been designed to accommodate handrail that terminates into the side of a post. The elongated slot makes them fully adjustable for a great fit. Made from marine-grade stainless steel, they can be powder coated to match your system. Available for wood posts or metal posts.



Wall-Mounted
Handrail Bracket

Grab Rail Bracket

Postside Handrail
Bracket
(new adjustable
design)



Glass Infill

Glass, Rods, or Cable: Viewrail knows how to save your view.



Residential & Commercial Glass Railing

A top choice for view preservation and safety for both interior and exterior applications, glass railing is a safe and stunning option. Modern, clear panels give the illusion of invisible railing while stainless steel fixture options provide strength and style.

Installation using any of our featured fixtures is intended to be simple, easily allowing perfect alignment of your glass panels through pressure-sensitive or tilt-and-lock features.

Viewrail Post Glass Railing

Viewrail Glass offers the clean look you expect from glass railing with the elegance of our architecturally correct posts. We have stainless steel glass clips that support 3/8" or 1/2" glass. Clips and posts can be powder coated to please a wide range of aesthetic tastes.

Viewrail Post Glass Barrier

Marine-grade stainless steel posts and clips provide a solid foundation to secure glass railing. As shown, the glass barrier posts are shorter than average allowing the glass panel itself to cleanly meet your railing height requirements.



Glass Clip
(front)



Glass Clip
(back)



Surface Mount
Glass Post

Baserail

The beauty of this baserail extends below its polished aluminum surface. Hidden fasteners within this sleek, floor level fixture tilt and lock for easy and perfect glass pane alignment. No top cap or stiffeners are required to achieve this elegant frameless look. If, however, you desire the look of a slimline cap or stiffeners, we offer a full lineup of stainless steel accessories.

Surface Mount Glass Brackets

Minimalistic features are the highlight of this glass mounting system. Surface affixed brackets made of stainless steel provide strength, beauty, and corrosion resistance. Designed for reliability and ease of adjustment, these fixtures use pressure on the screws, instead of tightening screws through static drilled holes. A cost-efficient modern solution for structural glass railing.

Side Mount Glass Brackets

Side mount brackets provide minimalistic features with an edge. Incorporating the surface material into the design of the railing, these modern stainless steel brackets provide a clean look and ease of adjustment for a picture perfect install. Designed to utilize pressure instead of drilled holes to hold the glass panel in place, the result is a railing that is strong and reliable.

Stand Off Pins

Offering a completely frameless look that utilizes the least possible amount of materials, Stand Off Pins invite creativity. They can be arranged in many flexible patterns and adjusted up to 8 millimeters, making them quite useful for attaching glass to a wide variety of surfaces.

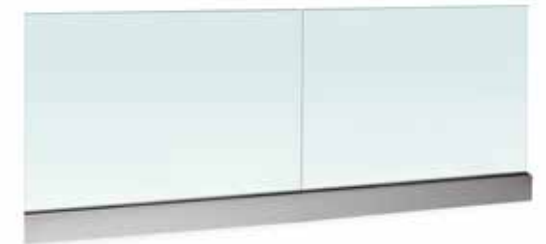



THE EVOLUTION OF RAILING

In 2018, the modern railing industry will witness the birth of something new.

Something better.

An infill that has the same petite profile as cable, but it will never sag.

An infill that can be precisely bent to handle curved applications.

An infill that has a smooth brushed finish that perfectly matches the texture of Viewrail's brushed stainless steel posts and handrail.

An infill made from 2205 stainless steel. It's so strong they used it to rebuild the support structure of the Statue of Liberty. It's so corrosion resistant they use it on offshore oil rigs.

You can call it a game-changer. We call it...

SLIM ROD RAILING

CALL VIEWRAIL TODAY TO LEARN MORE.

Cable Railing Infill



Cable Railing for Metal Posts

In recent years, cable railing has become synonymous with modern designs and elegant solutions for a wide variety of railing needs. At Viewrail, we continue to innovate products that will satisfy the creativity of our clients, while maintaining system strength and ease of installation.

Hidden Fasteners

Driven by a desire for simplicity and elegance, we've designed a system that keeps the cable mounting hardware out of sight, creating clean lines that won't distract from the beauty of the railing or the view.

Durability in any Climate

All of our components are machined from marine-grade stainless steel. If you're in a desert, a mountain range, or right on the ocean, these kits are going to provide you enduring strength and corrosion resistance.

Cable Railing with our Metal Posts elevates any modern decor.



Level Tension Kit

The Level Tension Kit consists of one Tension Receiver, one Threaded Crimp Fitting, and one Steel Insert Sleeve. This kit is used to mount one end of the cable to a metal post that has level through-holes.

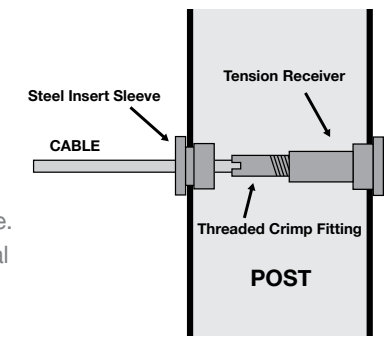

Angle Tension Kit

The Angle Tension Kit consists of one Tension Receiver, one Threaded Crimp Fitting, one Angle Washer, and one Adhesive Sleeve. This kit is used to mount one end of the cable to a metal post that has angled through-holes.

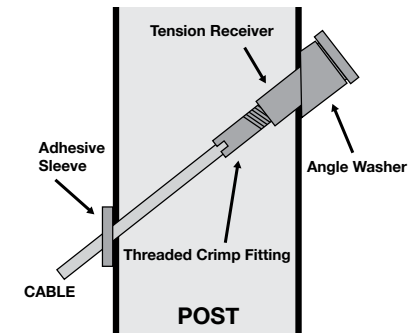

KeyMount Kit

The KeyMount Kit consists of one KeyMount Fitting and one Adhesive Sleeve. This kit works on both level and angle applications. The KeyMount Fitting can only be used with a Viewrail post that has been designed with keyholes to accept these specific fittings.

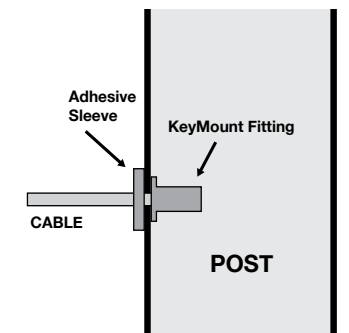

Stainless Steel Cable



Tension Receiver



Threaded Crimp Fitting



Angle Washer



KeyMount Fitting



Steel Insert Sleeve



Adhesive Sleeve

Cable Railing Infill



Cable Railing for Wood Posts

With all the same benefits shared in the previous section, the wood cable railing kits include some special components designed to perform specifically in wood posts, composite posts, or posts with vinyl sleeves.

Intermediate Posts

Viewrail offers three styles of intermediate posts as a solution for layouts that have more than 4' between main posts. These posts can be spaced evenly between main posts to keep cable deflection to a minimum. (8' max. between main posts)



**Intermediate Posts are not structural posts and do not offer handrail load support. They are for limiting cable deflection only.*



Stainless Steel Cable Tension Receiver

Great for wood & composite posts, these kits also work with post sleeves.



Wood Level Tension Kit

The Wood Level Tension Kit consists of one Tension Receiver, one Threaded Crimp Fitting, one Stainless Washer, and one Wood Insert Sleeve. This kit is used to mount one end of a level cable to a wood post.

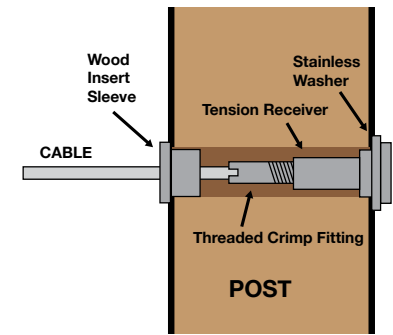

Wood Angle Tension Kit

The Wood Angle Tension Kit consists of one Tension Receiver, one Threaded Crimp Fitting, one Angle Washer, one Oval Washer, and one Wood Angle Insert. This kit is used to mount one end of an angled cable to a wood post.

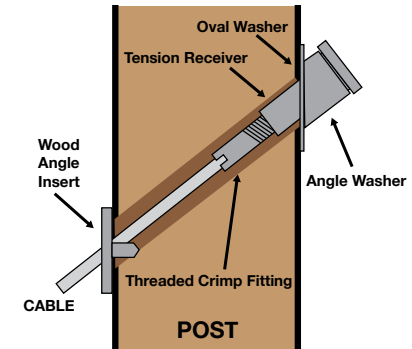

Threaded Crimp Fitting Angle Washer Stainless Washers Wood Insert Sleeve Wood Angle Insert

Crimpleless Cable



DriveTite

DriveTite for Wood Posts

If you're not a big fan of using crimpers, you're going to love DriveTite. Our unique mounting system utilizes a compression fit that is accomplished using familiar hand tools. This system is compatible with our standard Wood Tension Kits, making DriveTite a great option when you can't run cable through a post.

DriveTite Surface is Perfect for Hollow Posts

These hidden components mount to 2 1/2" solid posts or hollow posts with as little as 1 1/2" of mounting material. Capitalizing on the crimpleless DriveTite compression technique, DriveTite Surface makes installation even faster by eliminating the need for recess hole drilling.

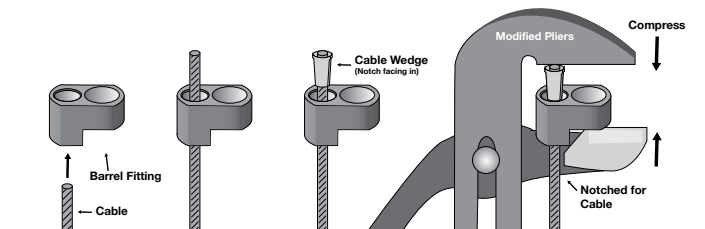

Tensioning Screw

Cable Wedge

Barrel Fitting



DriveTite Surface

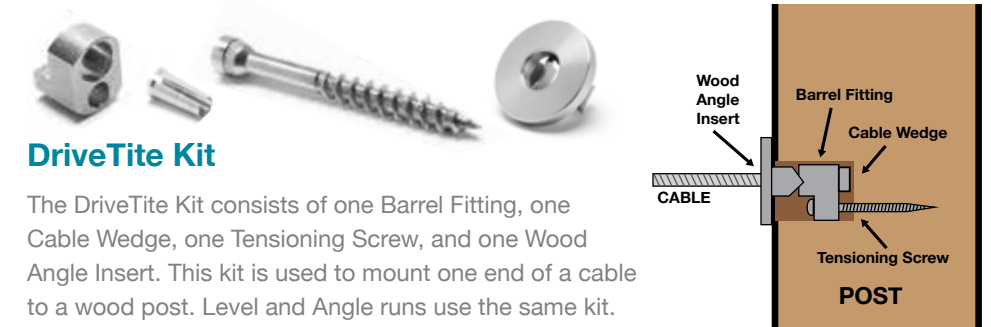

DriveTite Kit

The DriveTite Kit consists of one Barrel Fitting, one Cable Wedge, one Tensioning Screw, and one Wood Angle Insert. This kit is used to mount one end of a cable to a wood post. Level and Angle runs use the same kit.

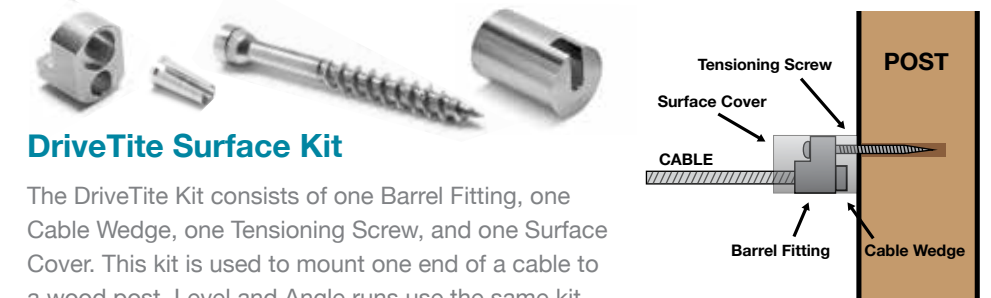

DriveTite Surface Kit

The DriveTite Surface Kit consists of one Barrel Fitting, one Cable Wedge, one Tensioning Screw, and one Surface Cover. This kit is used to mount one end of a cable to a wood post. Level and Angle runs use the same kit.

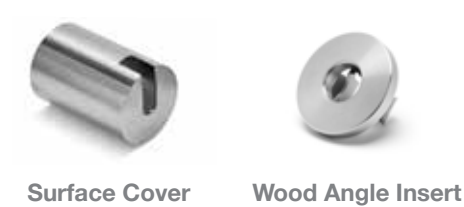

Surface Cover

Wood Angle Insert

Tools & Warranty

The Right Tools for the Job

Our specialized Installation Kits have everything you'll need to install your cable railing system. These are contractor-grade tools that have been hand selected to make your installation as efficient as possible.

Cable Railing Installation Kit

This Kit is used with our wood post and metal post cable railing systems. It contains:

- Crimper
- Cable Cutter
- Tightening Tool – used to hold Threaded Crimp Fitting
- Guide Pin – useful for threading Threaded Crimp Fitting
- 1/4" Allen Wrench – used to turn Tension Receiver
- Torx Bit – to drive post mounting screws
- Wood Block – for tapping in Insert Sleeves
- String – run through bottom hole of posts to check clearance on stairs

DriveTite Installation Kit

This Kit is used with our DriveTite and DriveTite Surface Kits for wood post systems. It contains:

- Cable Cutter
- Modified Pliers
- Torx Bit – to drive Tensioning Screws into wood posts
- Wood Block – for tapping in Insert Sleeves
- String – run through bottom hole of posts to check clearance on stairs
- Forstner Bit – used for drilling flat-bottom holes

Code Compliance & Warranty

Code Compliance for 4" Sphere

Meeting the 4" sphere rule means that cables should be spaced on the standard spacing provided in the Viewrail posts. The standard spacing is 3 1/8" on center, which allows a reasonable amount of deflection of the cable when the posts are spaced no more than 4' apart. When laying out a deck or balcony it is tempting to space posts farther than 4' apart, however the deflection of the cable increases dramatically and it cannot be overcome with increased tension. To conform to the 4" sphere rule, do not place posts more than 4' apart and do not space cables more than 3 1/8" apart. Often posts are placed adjacent to each other for a dual corner. When placing two posts in a corner, be sure to place them no more than 4" from each other.

Be sure to check with your local code official about your railing installation before placing your order. Codes are frequently interpreted differently by local code inspectors.

Viewrail Stainless Steel Cable and Fittings 10 Year Warranty

Viewrail warrants that all Viewrail stainless steel cable and fittings shall be free from defects in material and workmanship under normal use, conditions, installation and maintenance in accordance with product specifications for ten (10) years from date of purchase.

Warranty Information for Posts

Viewrail warrants that all Viewrail posts shall be free from defects in material and workmanship under normal use, conditions, installation and maintenance in accordance with product specifications for ten (10) years from date of purchase.

Warranty Information for Finishes

Viewrail warrants powder coat finishes as follows:

- Standard – 1 year for adhesion and color retention
- Fluoropolymer – 10 years for adhesion and color retention



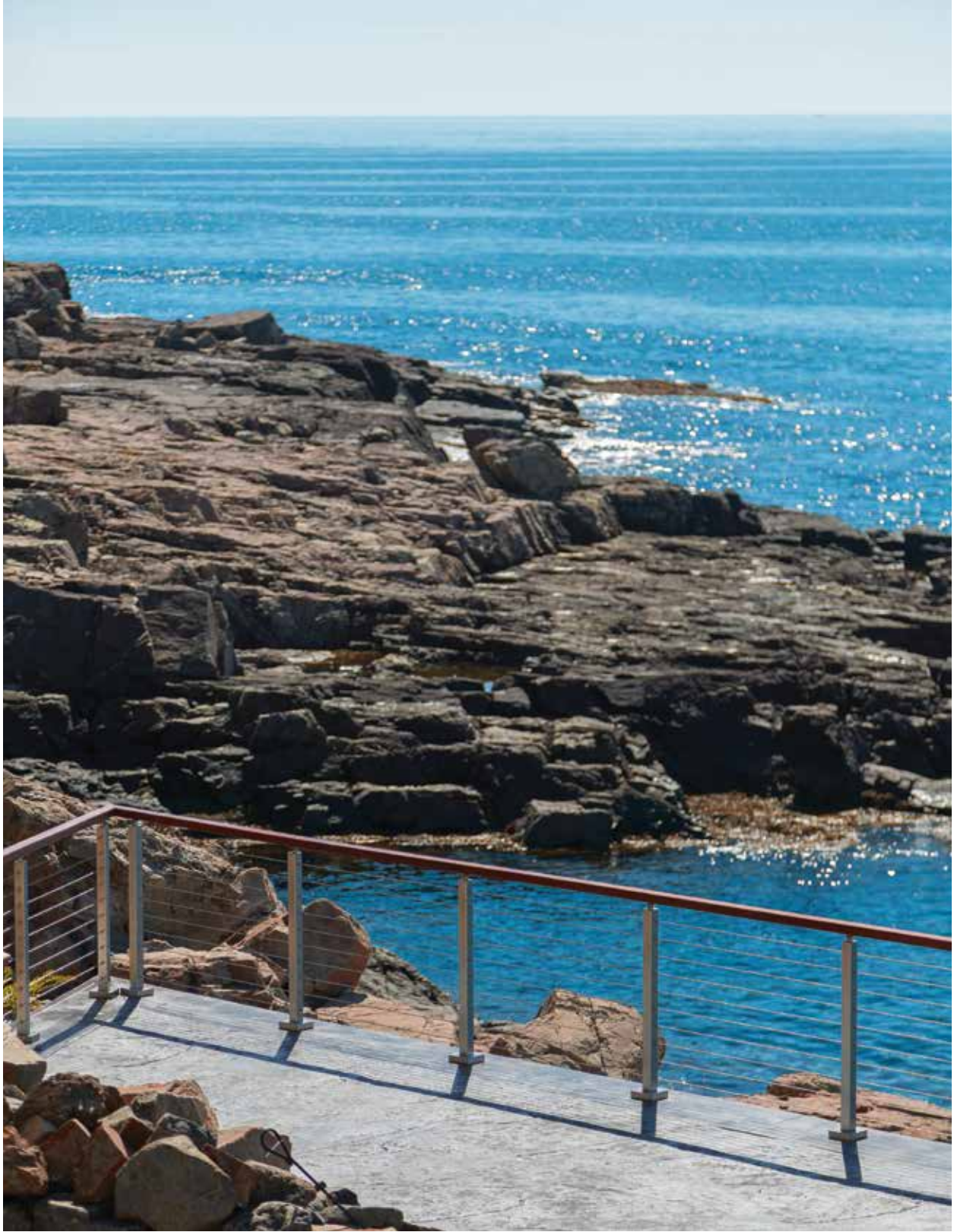

V I E W R A I L

1722 EISENHOWER DR. NORTH
GOSHEN, IN 46526
574-742-1030
ORDERS@VIEWRAIL.COM